

M-1000

MATTRESS TAPE EDGE MACHINE

YATAK KENAR KAPAMA MAKİNASI



Technical Details

Mattress tape edge machine is used since the early years of the industry. Through changing technology, manual mattress tape edge machine was changed, therefore the current manual mattress tape edge machine has become the choice of many manufacturers' choice thanks to the changing technology. Available both Lock Stitch and Chain Stitch sewing heads, Operator Carrying Platform, Automatic slowing down at the corner of mattresses, Adjustable Straight Sewing and Corner Turning speeds, able to sew 5cm to 32 cm mattresses.

Teknik Özellikler

Yatak kenarı kapama makinesi sektörün ilk yıllarından beri kullanılan makinedir. Değişen teknoloji sayesinde şu anki son halini alan manuel kenar kapama makinesi birçok üreticinin tercihi haline gelmiştir. Kilit dikiş ve zincir dikiş dikiş kafaları opsiyonu, operatörü taşıma platformu, köşe dönüşlerde otomatik yavaşlama, ayarlanabilir düz ve köşe dönüş hızları, 5 cm den 32 cm yüksekliği kadar dikiş dikebilme



Has the feature of carrying its operator over itself.
Operatörünü kendi üzerinde taşıma özelliği.



Possibility of control with three foot pedals.
Ayaktan üç adet pedalla kontrol imkânı.



Speed of flat and turning corner are adjusted by electronic potentiometer.
Düz dikiş ve köşe dönüş hızları elektronik potansiyometre ile ayarlı.



Automatically slows down when turning the corners.
Köşe dönüşlerde otomatik yavaşlama.



Electronic driver control.
Elektronik sürücü kontrollü.



Heavy duty carriage on 80*20 lamination structure.
80*20 lamination üzerinde sağlam ve uzun ömürlü yürüyüş takımı.



Chain or lock stitch sewing head option.
Zincir ve kilit dikiş makine seçeneği.



Optional table height range adjustment with motor
Opsiyonel motorlu tabla kaldırma ayarı
Table lifting range
Tabla kaldırma kolu

M-1000 / MATTRESS TAPE EDGE MACHINE

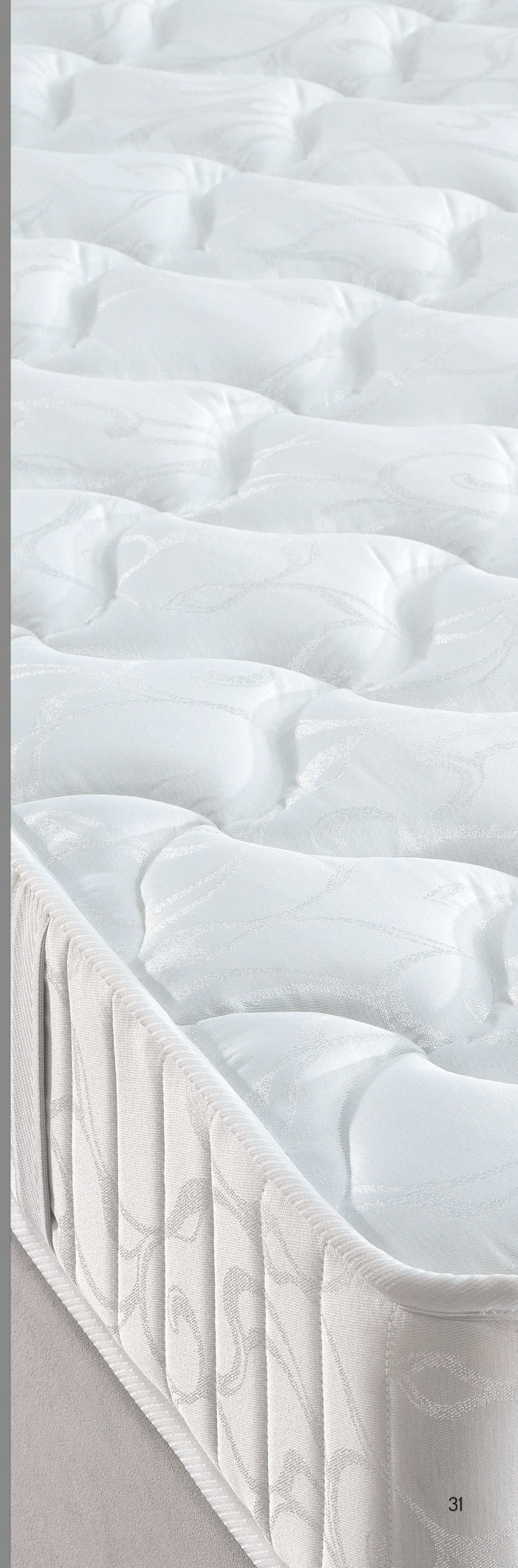

M-1000

TECHNICAL DETAILS

MATTRESS TAPE EDGE MACHINE

YATAK KENAR KAPAMA MAKİNASI

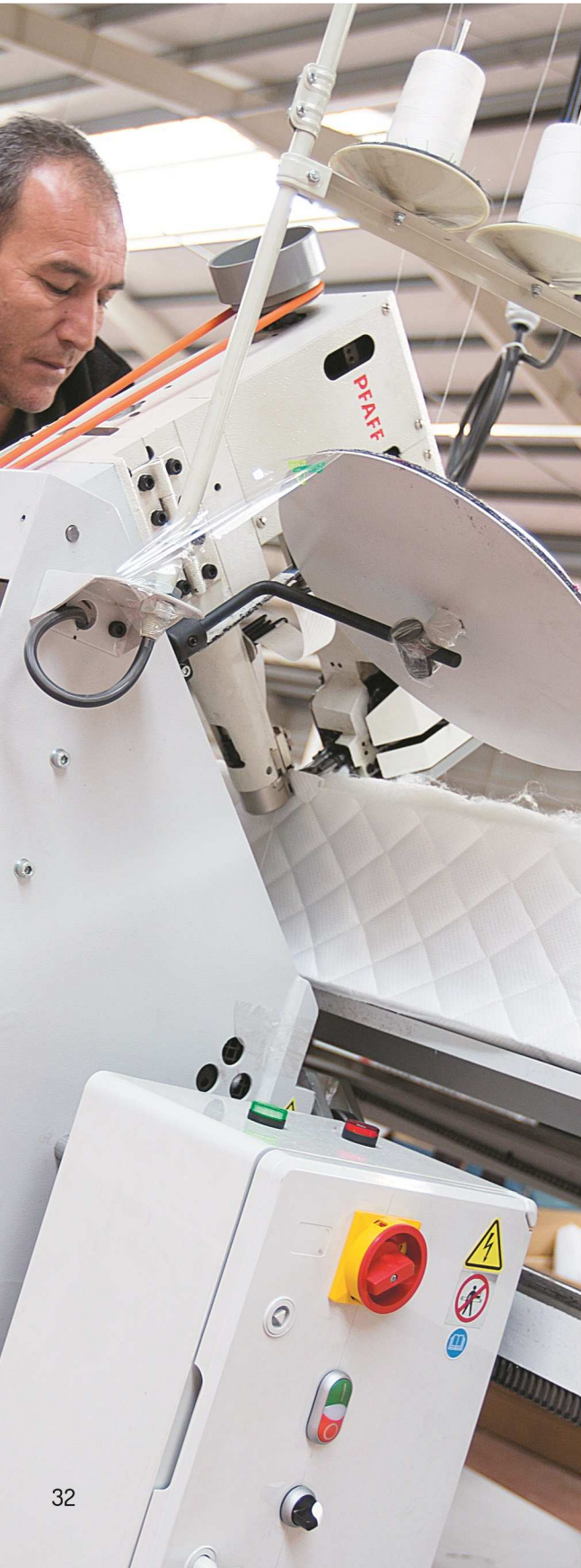

| DEFINATION / TANIM | M-1000 MATTRESS TAPE EDGE MACHINE M-1000 YATAK KENAR KAPAMA MAKİNASI |
|--|---|
| Sewing Machine Dikiş Makinası | PFAFF 335 (optional CTECH 300U on request) PFAFF 335 (CTECH 300U – opsiyonel) |
| Production Capacity Üretim Kapasitesi | Up to 120 mattress in 8 hours depends on operator performance Operatör hızına bağlı olarak 8 saatte 120 yatak |
| Lock Stitch Technology Kilit Dikiş Teknolojisi | Lock Stitch Technology is used for high-quality production Yüksek kaliteli üretim için kilit dikiş teknolojisi kullanılır |
| Table Size Masa Ölçüleri | 149 cm x 217 cm (width x lenght) 149 cm x 217 cm (en x boy) |
| Dimension Makine Ölçüleri | 149 cm x 263 cm x 104 cm cm (width x lenght x height) 149 cm x 263 cm x 104 cm (en x boy x yükseklik) |
| Mattress Height Yatak Yüksekliği | 5 cm – 32 cm (50 cm is available on request) 5 cm – 32 cm |
| Weight Kilo | 600 Kgs 600 Kg |
| Sewing Speed Dikiş Hızı | 3000 rpm / 15000 mm stitch lenght 3000 rpm / 15000 mm dikiş uzunluğu |
| Sewing Guide Number Apara Numaraları | Number of sewing guide used for tape edge machine is like that : 18,20,22,24,26,...42,45 Kenar kapama makinasında kullanılan apara numaraları şu şekildedir; 18,20,22,24,26,...42,45 |
| Type Of Sewing Guide Apara Tipi | Standard sewing guide is used for sewing head with shuttle (PFAFF 335) Mekikli dikiş makinasında (PFAFF 335)çentiksiz dikiş aparası kullanılır |
| Thread İplik | "It is recommended number 40 double-sides 75 tex polyester sewing thread as up thread; Number 80 double-sides 40 tex polyester sewing thread as bottom thread Mekikli makinalarda üst ip olarak 40 numara çift ilikli 75 tex polyester dikiş ipliği; alt ip olarak da 80 numara çift ilikli 40 tex polyester dikiş ipliğinin kullanılması tavsiye edilir" |
| Needle İğne | It is recommended number 130/21C needle for PFAFF 335 PFAFF 335 için 130/21C numaralı iğnelerin kullanılması tavsiye edilir |
| Tape Edge Fital | It can be used tape edge according to sewing guide Apara uygun olarak fitil kullanılabilir |
| Overlock Overlok | Making overlock around of thick material quilting is easier to make tape edge and provides a smooth appearance Kalın malzemeli kapitone çevresinin overlok yapılması hem kenar kapamanın yapılmasını kolaylaştırır hem de daha düzgün bir görünüm sağlar |
| Power Requirements Enerji | 3 Phase 380 V / 4,5 kW 3 Faz 380 V / 4,5 kW |
| Required Set-Up Area Kurulum Alanı | 2.5 m x 3 m (width x lenght) 2.5 m x 3 m (en x boy) |
| Required Loading Area Yükleme Alanı | 1.6 m x 2.3 m (width x lenght) 1.6 m x 2.3 m (en x boy) |
| Number of Personnel Personel Sayısı | 1 1 |
| Quality Standard Kalite Standartı | CE CE |
| Warranty Garanti | 2 Years 2 Yıl |

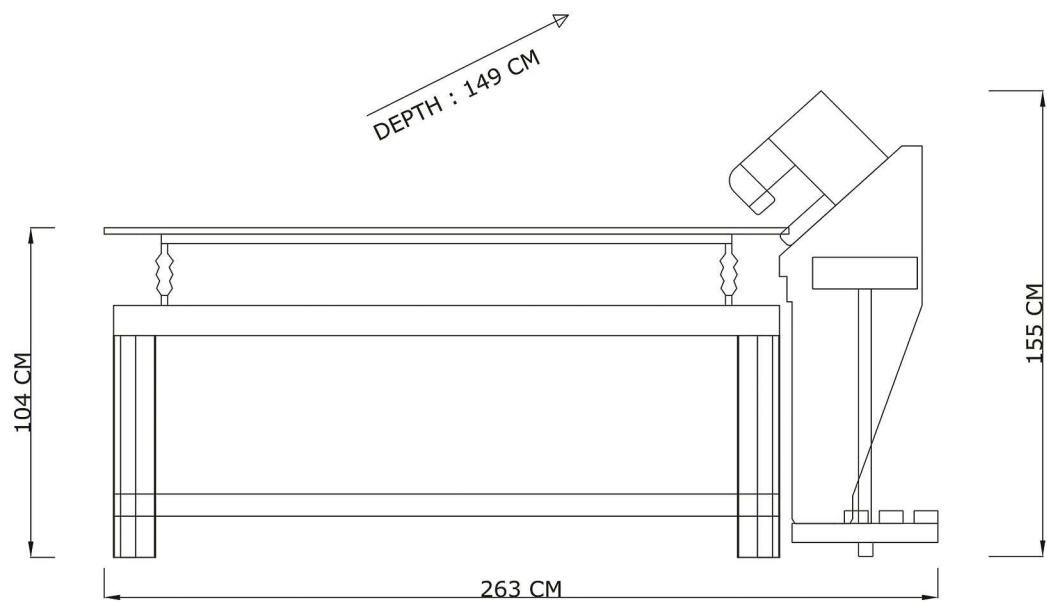

Low noise and vibration and stable performance
Az ses ve titreşim ve sabit performans



Adjustable straight line sewing speed
Ayarlanabilir düz dikiş hızı



Head lifting range
Dikiş kafası kaldırma kolu
Manual adjusting table height and sewing head angle
Manuel olarak masa yüksekliği ve kafa çapı ayarlama



Adjustable position of the operator carriage around the table for small mattress
Küçük yataklar için tablanın etrafındaki pozisyonu ayarlanabilir operatör taşıyıcı



M-1000 / MATTRESS TAPE EDGE MACHINE



NORDIMETA INDUSTRIAL SERVICES
Comércio e Assistência a Equip. Industriais, Lda.